

ALIGNMENT

ALIGNMENT INFORMATION

Proper alignment of the driver shaft and the driven shaft eliminates vibration, maximizes bearing life, and extends the overall life of the machinery. It also improves the efficiency of the driver, which reduces power consumption. Ideally, the shaft axes should form one continuous line.

A common obstacle to proper alignment is a "soft foot." This occurs when not all of the mounting feet are in the same plane, causing the frame to twist as the foot is tightened.

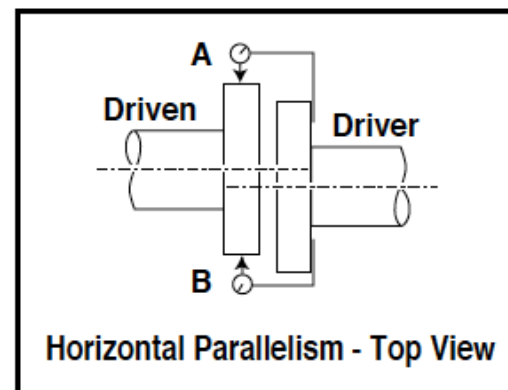
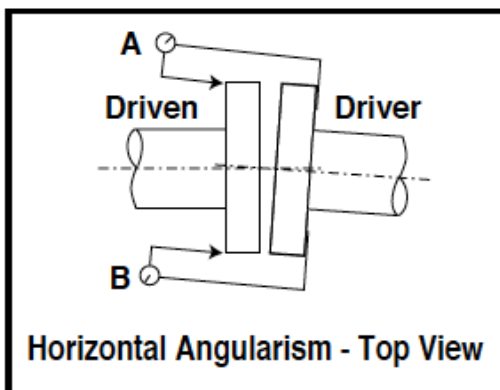
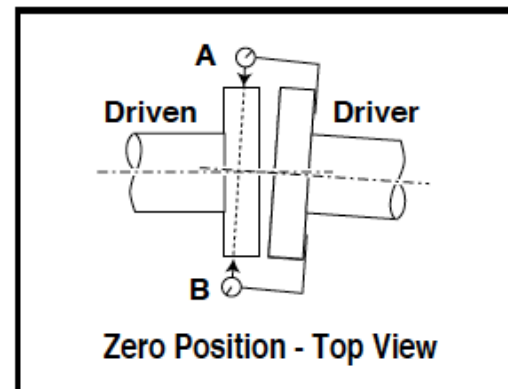
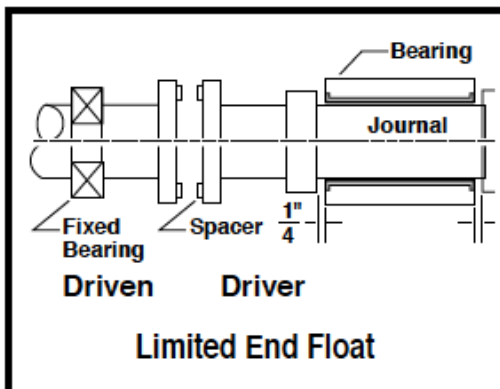
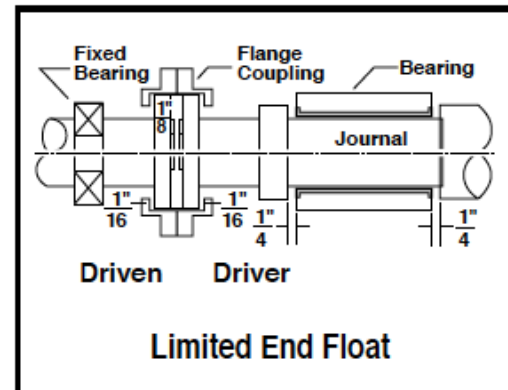
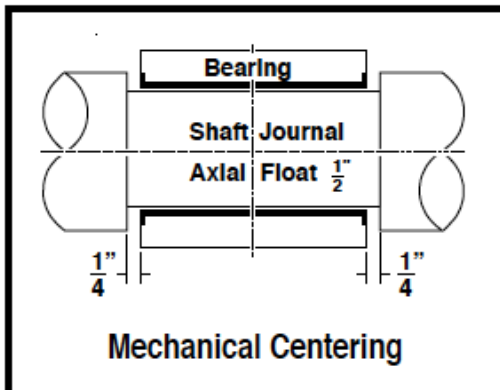
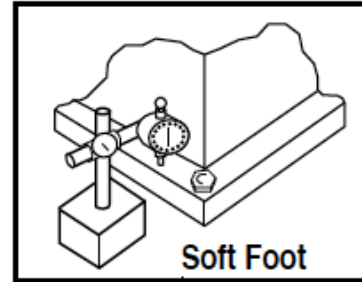

SUGGESTED ALIGNMENT TOLERANCES

These suggested alignment tolerances are the desired values, whether such values are zero or a targeted offset. They should be used only if machinery manufacturer alignment tolerances are not available.

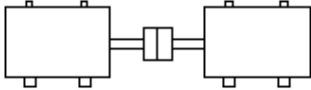
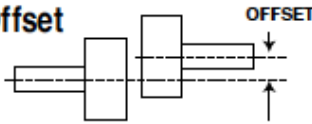
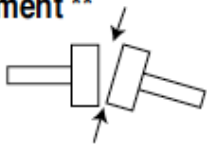
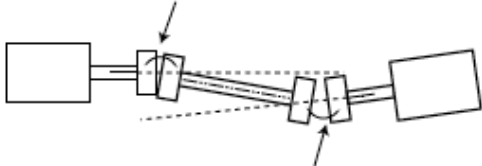
	RPM	INSTALLATION	IN SERVICE
Soft Foot (mils) *	All	± 1.0	± 1.5
Short Couplings			
			
• Parallel Offset (mils)			
		1200	± 1.25
		1800	± 1.0
		3600	± 0.5
• Angular Misalignment ** (mils/inch)			
		1200	0.5
		1800	0.3
		3600	0.2
Couplings With Spacers			
			
Parallel Offset			
Per Inch of Spacer	1200	0.9	1.5
Length (mils/inch)	1800	0.6	1.0
	3600	0.3	0.5

* "Soft foot" describes the condition where the four mounting feet are not all in the same plane. Measured in mils (1 mil. = .001 inches).

** To find angular misalignment in mils/inch of coupling diameter, measure widest opening in mils, then subtract narrowest opening in mils, and divide by diameter of coupling in inches.

Note: Up and down motion of driving and driven shafts with temperature may be in either direction.